

SECTION 05: SPEEDWAY® CABLE LADDER SYSTEMS



Speedway® Cable Ladder Systems provide faster and easier installation, combined with our unique coupler locking system and comprehensive range of accessories.

Manufactured in 3 heights:

- Speedway® 4 (SW4) - 110mm overall height
- Speedway® 5 (SW5) - 125mm overall height
- Speedway® 6 (SW6) - 150mm overall height

Special Profiled Side Section:

1. Enhanced structural rigidity.
2. Increased internal width for cables.
3. High performance coupling.
4. Safety edge.

Slotted Side Section:

1. Allows faster installation as the ladder can be cut to any length and coupled without on-site drilling.
2. Fixing to ladder sides.
3. Reduced weight.

Shallow Channel Rungs:

1. The welding of the rungs to the lowest point of the side section ensures maximum loading height.
2. High strength even in the widest ladders.
3. Compatible with every known type of cleat, tie and bonding with infinite adjustment.
4. Rungs alternately inverted (on lengths) permitting suspension of light fittings etc. from underside.

ACCREDITED TO THE FOLLOWING STANDARDS:



Speedway® Cable Ladder is supplied in various materials and finishes:



Ladder & Fittings

-  Hot dip galvanized Vantrunk Structural Steel (Steel BS EN 10025-2 and Galvanising BS EN 1461)

Covers & Accessories

-  Hot dip galvanized Mild Steel (Steel BS EN 10111 and Galvanising BS EN 1461)

Ladder, Fittings, Covers & Accessories

-  Deep galvanised structural steel (Steel BS EN 10025-5 and Galvanising BE EN 1461)
-  Stainless steel grade 1.4404 (316L marine) to BS EN 10088-2

The Speedway® Cable Ladder System is subject to Registered Design, Trade Mark and Patent considerations and conforms to BS EN 61537.



Speedway® SW4 Cable Ladder

Speedway® 4 (SW4) Medium Duty Cable Ladder is manufactured in 3m lengths as standard, 6m lengths available to order.

Available in standard widths of 150mm, 300mm, 450mm, 600mm, 750mm, 900mm and 1050mm. Widths up to 1200mm are available to order.

Rung spacing is 300mm as standard.

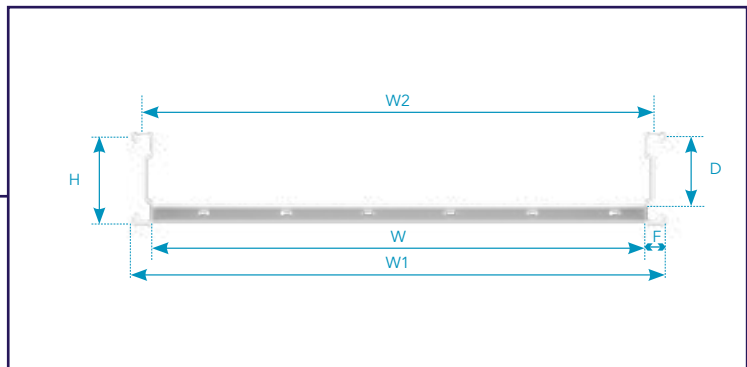
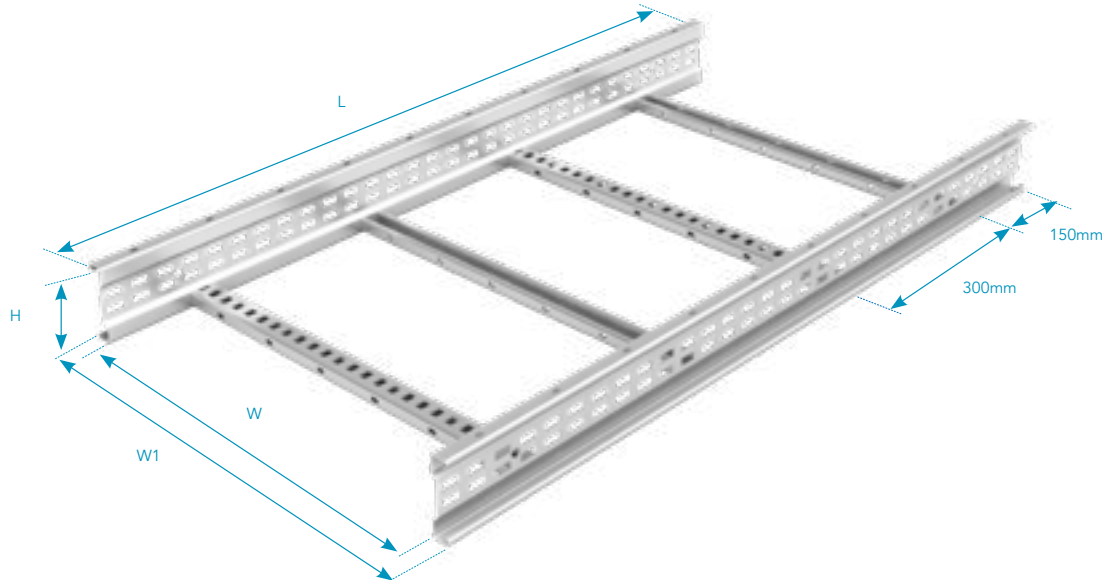

Part Number	No. of Rungs	Dimensions (mm)				Weight* (kg)
		W	W1	L	H	
SW4-SL3-150-○	10	150	200	3000	110	13.93
SW4-SL3-300-○		300	350			15.55
SW4-SL3-450-○		450	500			17.17
SW4-SL3-600-○		600	650			18.79
SW4-SL3-750-○		750	800			23.12
SW4-SL3-900-○		900	950			25.28
SW4-SL3-1050-○		1050	1100			27.34

Height	H	110mm
Loading Depth	D	85mm
Ladder Width	W	100mm to 1050mm
Overall Width	W1	W + 50mm
Maximum Internal Width	W2	W + 14mm
Flange Width	F	25mm

○ = Select a finish/material (Refer to page 22)
Weights shown are for Hot Dip Galvanised finish only.

QuickFix Trunking

QuickFix Multi Compartment Trunking

Lighting Trunking

Uniklip Cable Tray

Speedway Cable Ladder Pre-Galv. Cable Ladder

Cable Basket Systems

Channel & Support

Floor Trunking

Bench Outlet & Perimeter Trunking

Steel Conduit (Class 4)

Innovative Design Solutions

Accessories & Supports

Index

SPEEDWAY® CABLE LADDER SYSTEMS

Speedway® SW5 Cable Ladder

Speedway® 5 (SW5) Heavy Duty Cable Ladder is manufactured in 3m lengths as standard, 6m lengths available to order.

Available in standard widths of 150mm, 300mm, 450mm, 600mm, 750mm, 900mm and 1050mm. Widths up to 1200mm are available to order. Rung spacing is 300mm as standard.

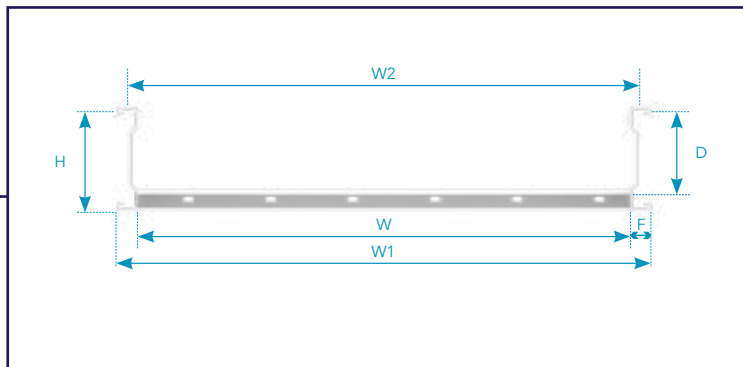
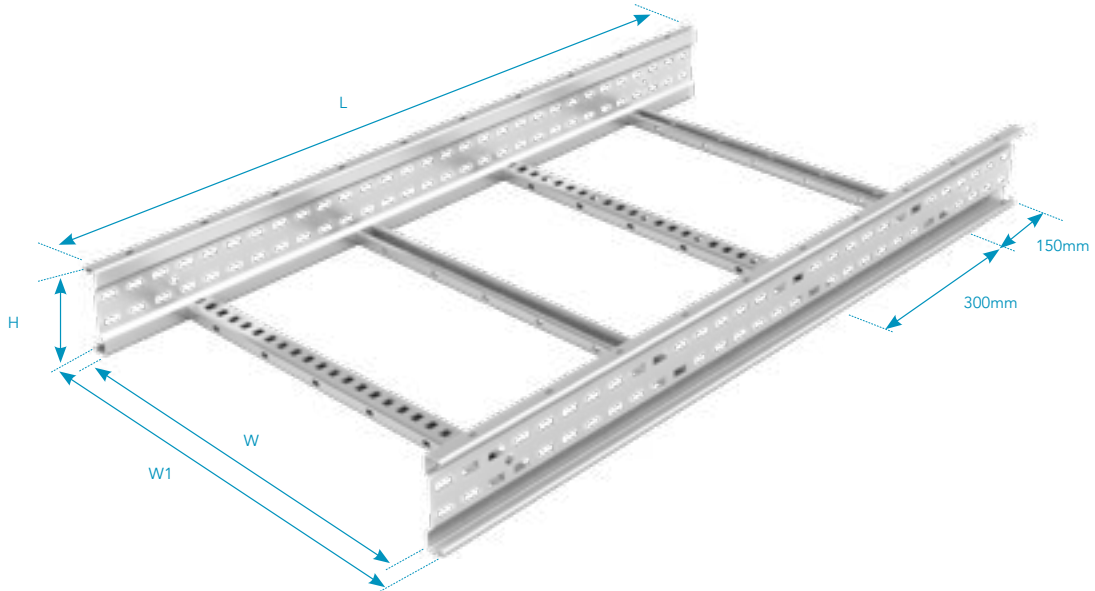

Part Number	No. of Rungs	Dimensions (mm)				Weight* (kg)
		W	W1	L	H	
SW5-SL3-150-○	10	150	200	3000	125	18.53
SW5-SL3-300-○		300	350			20.15
SW5-SL3-450-○		450	500			21.77
SW5-SL3-600-○		600	650			23.40
SW5-SL3-750-○		750	800			27.72
SW5-SL3-900-○		900	950			29.88
SW5-SL3-1050-○		1050	1100			32.05

Height	H	125mm
Loading Depth	D	100mm
Ladder Width	W	100mm to 1500mm
Overall Width	W1	W + 50mm
Maximum Internal Width	W2	W + 14mm
Flange Width	F	25mm

○ = Select a finish/material (Refer to page 22)
Weights shown are for Hot Dip Galvanised finish only.



Speedway® SW6 Cable Ladder

Speedway® 6 (SW6) Extra Heavy Duty Cable Ladder is manufactured in 3m lengths as standard, 6m lengths available to order.

Available in standard widths of 150mm, 300mm, 450mm, 600mm, 750mm, 900mm and 1050mm. Widths up to 1200mm are available to order.

Rung spacing is 300mm as standard.

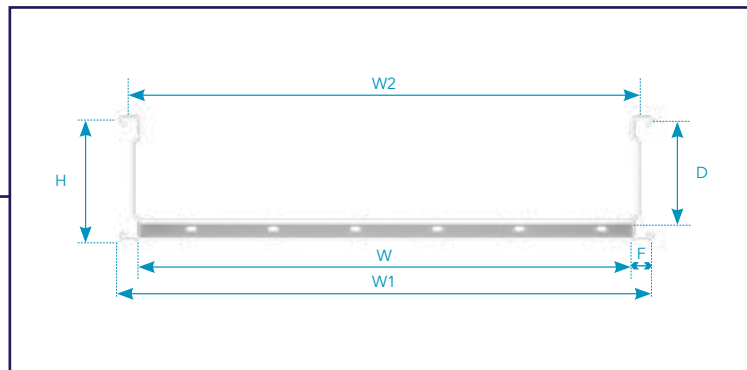
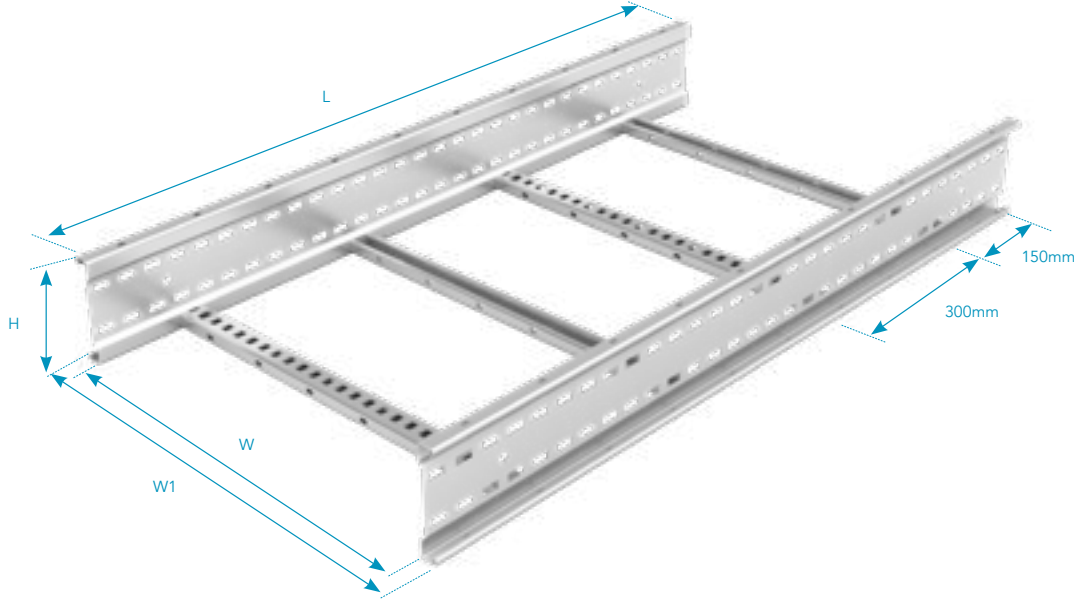

Part Number	No. of Rungs	Dimensions (mm)				Weight* (kg)
		W	W1	L	H	
SW6-SL3-150-○	10	150	200	3000	150	17.02
SW6-SL3-300-○		300	350			18.65
SW6-SL3-450-○		450	500			20.28
SW6-SL3-600-○		600	650			21.90
SW6-SL3-750-○		750	800			26.08
SW6-SL3-900-○		900	950			28.22
SW6-SL3-1050-○		1050	1100			30.35

Height	H	150mm
Loading Depth	D	125mm
Ladder Width	W	100mm to 1500mm
Overall Width	W1	W + 50mm
Maximum Internal Width	W2	W + 14mm
Flange Width	F	25mm

○ = Select a finish/material (Refer to page 22)
Weights shown are for Hot Dip Galvanised finish only.

QuickFix Trunking

QuickFix Multi Compartment Trunking

Lighting Trunking

Uniklip Cable Tray

Speedway Cable Ladder Pre-Galv. Cable Ladder

Cable Basket Systems

Channel & Support

Floor Trunking

Bench Outlet & Perimeter Trunking

Steel Conduit (Class 4)

Innovative Design Solutions

Accessories & Supports

Index

Cable Ladder Fitting with Integral Coupler

This fast-fitting system offers significant cost saving through reduction of the number of couplers and fixings required. The integral coupler has a formed shape which increases strength and rigidity, and reduces joint hinging.

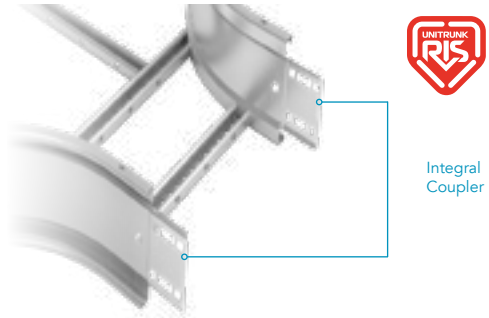

Flat Elbow 30°, 45°, 60° & 90°



Code

SW△-FE Angle-Width-Radius-Finish

Equal Cross



Code

SW△-EC-Width-Radius-Finish

Equal/Unequal Tee

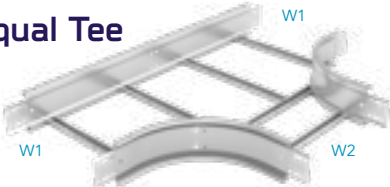

Code

SW△-ET-Width-Radius-Finish

Type

Equal

SW△-UT-W1-W2-Radius-Finish

Unequal

Covers



Code

SW△-CC-SL1.5-Width-Finish

Type

Closed

Supplied with fixings. Straight ladder covers are supplied in 1.5m lengths.

SW△-CL-SL1.5-Width-Finish

Louvered

Riser (Outside) 30°, 45°, 60° & 90°



Code

SW△-OR Angle-Width-Radius-Finish

Short Adjustable Coupler



Code

SW△-SAC-Finish

Overall length 300mm. Used as an alternative to Reducers and Unequal Tees. Supplied with fixings.

Riser (Inside) 30°, 45°, 60° & 90°



Code

SW△-IR Angle-Width-Radius-Finish

Straight Coupler



Code

SW△-CS-Finish

Sold in pairs. Supplied with fixings. 1 Pair per ladder.

△ = Select a system type

Long Adjustable Coupler



Code
SW△-LAC-Finish

Overall length 450mm. Used as an alternative to Reducers and Unequal Tees. Supplied with fixings.

Adjustable Fixing Bracket



Code
SW-afb-Finish

Supplied with 1 fixing.

External Flange Clamp



Code
SW-EFC-Finish

Fixings ordered separately.

Horizontal Adjustable Coupler



Code
SW△-HAC-Finish

Sold singly. Each supplied with fixings.

Hold-Down Bracket



Code
SW△-HDB-Finish

Fixings ordered separately.

Vertical Adjustable Coupler



Code
SW△-VAC-Finish

Sold singly. Each supplied with fixings. Identical for SW4 & SW5 - order as: SW4-5-vac-finish. For SW6 order as: SW6-vac-finish.

Straight Ladder Divider



Code
SW△-DIV-SL1.5-Finish

Straight ladder dividers are 1.5m long. Fixings ordered separately.

Reducer Left Hand

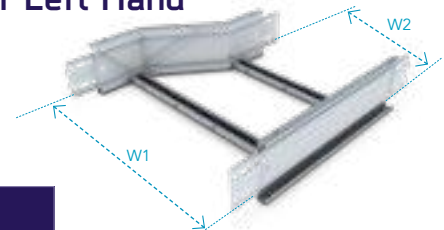

Code
SW△-RL-W1-W2-Finish

Straight Reducer



Code
SW△-RS-W1-W2-Finish

Reducer Right Hand

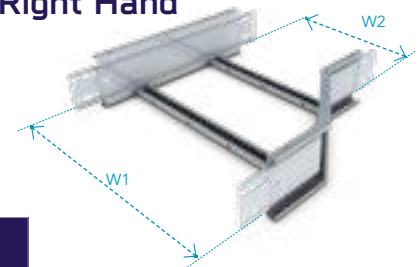

Code
SW△-RR-W1-W2-Finish

△ = Select a system type

SPEEDWAY® CABLE LADDER SYSTEMS

Ladder Fixing Kit



Code

VSFK/G

Sold in packs of 8.

Earth Braid



Designed for use in installations where an additional means of earthing or electrical bonding is specified.

Comprised of a 16mm² tinned copper braid crimped into M10 tinned copper end connectors.

The Speedway® Earth Braid/Bonding Strap is compatible with Speedway® SW4, SW5 & SW6.

Code

EBS-01 (M10 BRAID)

Pre-punched holes for fixing the earth bonding strap are located at each end of the ladder and fittings.

Loading Data

The below table information is indicative of the performance of Speedway® SW4, SW5 and SW6 Cable Ladder in a typical continuous beam installation.

The loading figures have been determined by actual load tests.

For detailed loading data please contact our technical department.

System Type	Safe Working Load (kg/m)								
	2.0m	2.5m	3.0m	3.5m	4.0m	4.5m	5.0m	5.5m	6.0m
Speedway® SW4	293	293	293	293	185	-	-	-	-
Speedway® SW5	-	-	293	293	224	175	140	-	-
Speedway® SW6	-	-	-	-	293	230	185	151	125

The brackets shown below are compatible with Speedway® Cable Ladder Systems.



Fixed Angle Bracket 30° & 60°



Part Code

SW△LB1-○

Used for mounting lighting units at angles of either 30° or 60°. Fixed to both the sidewall and the base of the cable ladder. Supplied singly.

Fixed Angle Bracket 0° & 45°



Part Code

SW△LB2-○

Used for mounting lighting units at angles of either 0° or 45°. Fixed to both the sidewall and the base of the cable ladder. Supplied singly.

Adjustable Angle Bracket



Part Code

SW△LB3-○

Used for mounting lighting units at adjustable angles. Fixed to both the sidewall of the cable ladder or on either side of the rung. Supplied singly.

Ancillary Rung Bracket



Part Code

SW△LB4-Width-○

Used to add an additional rung where required to ensure compatibility with a lighting unit mounting pitch. Can be assembled with the continuous open face of the rung up or down and can be mounted so that the mounting face is flush with the ladder's rungs or with a drop of up to 85mm. Supplied singly.

Hold-Off Bracket



Part Code

SW-LB6-○

Used for mounting lighting units to both the sidewall of the cable ladder or the open face of the rung. Supplied Singly.

△ = Select a system type

○ = Select finish

Product Available in:

